

TGS1820 - for the detection of Acetone

Features:

- * High sensitivity and selectivity to acetone
- * Low interference from ethanol and hydrogen
- * Quick response
- * Compact
- * Low power consumption

Applications:

- * Acetone detectors
- * Breath acetone testers

TGS1820 is a hot wire semiconductor type gas sensor. The sensing element consists of a noble metal coil embedded in a small bead of sintered metal oxide semiconductor material. Electrical conductivity change caused by gas adsorption on the MOS material surface can be measured between both ends of the noble metal coil as a change in the combined resistance of the MOS material and the noble metal coil.

TGS1820 has high sensitivity to acetone with small interference from ethanol and hydrogen. This feature makes the sensor ideal for breath acetone analysis.



The figure below represents typical sensitivity characteristics, all data having been gathered at standard test conditions (see reverse side of this sheet). The Y-axis is indicated as sensor output voltage (bridge output) difference ΔV_{OUT} , which is defined as follows:

$$\Delta V_{OUT} = V_b (\text{Gas}) - V_b (\text{Air})$$

$$V_b = \text{Sensor output voltage (bridge output)}$$

The figure below represents typical gas response curves. Again, the Y-axis is indicated as sensor output voltage (bridge output) difference ΔV_{OUT} , which is defined as follows:

$$\Delta V_{OUT} = V_b (\text{Gas}) - V_b (\text{Air})$$

$$V_b = \text{Sensor output voltage (bridge output)}$$

Sensitivity Characteristics:

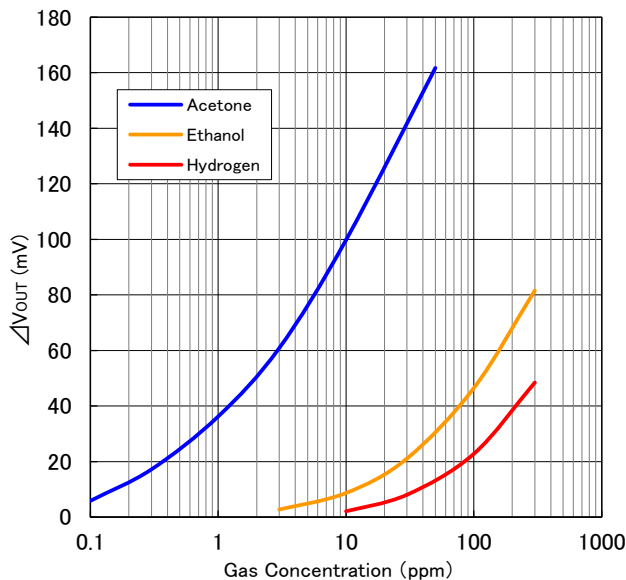

Gas Response:

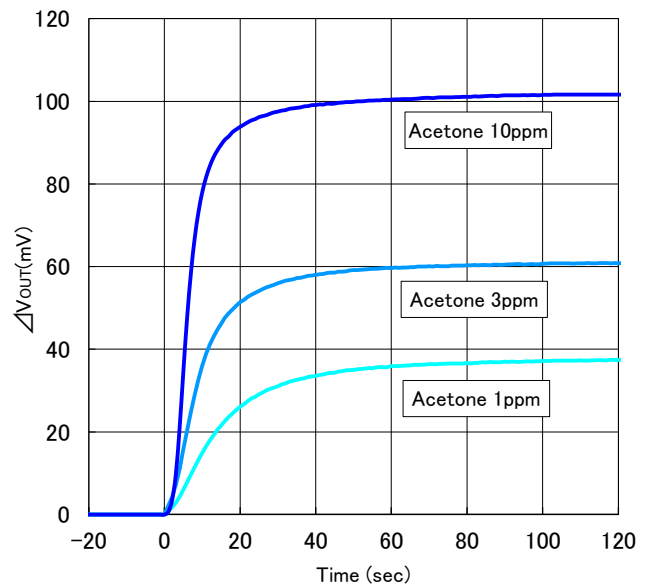

IMPORTANT NOTE: OPERATING CONDITIONS IN WHICH FIGARO SENSORS ARE USED WILL VARY WITH EACH CUSTOMER'S SPECIFIC APPLICATIONS. FIGARO STRONGLY RECOMMENDS CONSULTING OUR TECHNICAL STAFF BEFORE DEPLOYING FIGARO SENSORS IN YOUR APPLICATION AND, IN PARTICULAR, WHEN CUSTOMER'S TARGET GASES ARE NOT LISTED HEREIN. FIGARO CANNOT ASSUME ANY RESPONSIBILITY FOR ANY USE OF ITS SENSORS IN A PRODUCT OR APPLICATION FOR WHICH SENSOR HAS NOT BEEN SPECIFICALLY TESTED BY FIGARO.

Basic Measuring Circuit:

Basic measuring circuit for TGS1820 is shown in figure on the right. Circuit voltage is applied between both ends of the sensor and a load resistor, which are connected in series. Appropriate circuit voltage, which also works as heater voltage, and a load resistor of appropriate value should be determined in order to maintain the sensing element at a specific temperature which is optimal for gas sensing.

The bridge output or sensor output is measured from a Wheatstone bridge consisting of the sensor, a load resistor and two opposite side resistors as shown in the basic measuring circuit.

$$V_b = V_{RL} - V_{REF}$$

By using a high-resolution voltmeter, sensor response can also be monitored by measuring voltage changes across the load resistor without a Wheatstone bridge circuit.

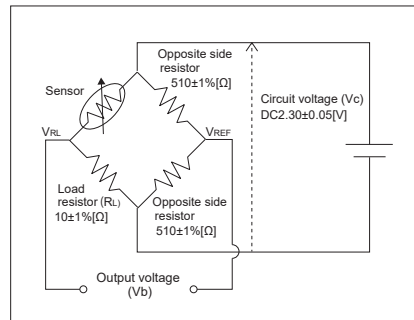

Specifications:

Model number		TGS1820	
Sensing principle		Hot wire semiconductor type	
Standard package		Plastic base and metal can	
Target gases		Acetone	
Typical detection range		1 ~ 20ppm	
Operating temperature and humidity		0 ~ 40°C, 10 ~ 80%RH	
Standard circuit conditions	Circuit voltage	2.30±0.05V DC	
	Load resistance	10Ω ±1%	
	Opposite side resistance	510Ω ±1% (variable)	
Electrical characteristics under standard test conditions	Power consumption	125mW	
	Sensor current	≤ 85mA	
	Sensor output Vb (Air)	-370 ~ -290mV	
	ΔV (1ppm Acetone) *	20 ~ 60mV	
	Sensitivity to Acetone	1.4 ~ 2.5	$\frac{\Delta V(3\text{ppm Acetone})}{\Delta V(1\text{ppm Acetone})}$
	Ethanol interference	≤ 1.0	$\frac{\Delta V(10\text{ppm Ethanol})}{\Delta V(1\text{ppm Acetone})}$
Hydrogen interference	≤ 1.0	$\frac{\Delta V(10\text{ppm H}_2)}{\Delta V(1\text{ppm Acetone})}$	
Standard test conditions	Test gas conditions	20±5°C/60±5%RH	
	Circuit conditions	Circuit voltage: 2.30±0.05V DC Load resistance: 10Ω ±1% Opposite side resistance: 510Ω±1%	
	Preheating period before test	≥ 1 hour	
Life expectancy at 20°C/60%RH in normal air		> 2 years	

$$*\Delta V = \Delta V_{OUT} = V_b(\text{Gas}) - V_b(\text{Air})$$

Structure and Dimensions:

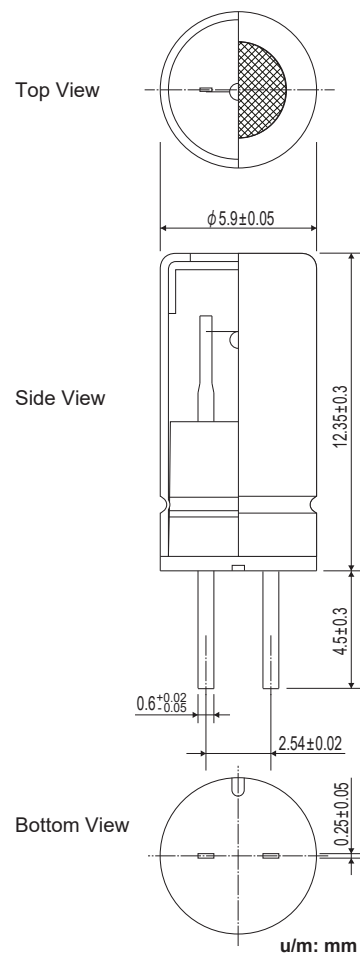

NOTE: There is no polarity between two pins.

All sensor characteristics shown in this brochure represent typical characteristics. Actual characteristics vary from sensor to sensor. The only characteristics warranted are those in the Specification table above.

Before purchasing this product, please read the Warranty Statements shown in our webpage by scanning this QR code.



https://www.figaro.co.jp/en/pdf/Limited_Warranty_en.pdf

FIGARO ENGINEERING INC.

1-5-11 Senba-nishi
Mino, Osaka 562-8505 JAPAN
Phone: (81)-727-28-2045
email: figaro@figaro.co.jp
www.figaro.co.jp